

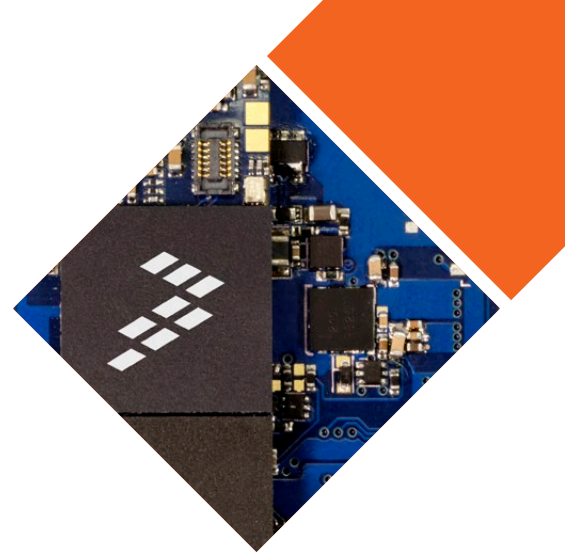

Wearable Reference Platform



Wearables Reference Platform (WaRP)

Overview

Wearables are devices that have been available for quite a while—devices such as headsets, smart watches and pedometers. However, this market segment is exploding and encompasses multiple verticals with added connectivity and capabilities. The Wearables Reference Platform (WaRP) provides wearable device manufacturers the opportunity to innovate and take to market a differentiated product faster. WaRP has been designed with a hybrid architecture that is scalable, modular and addresses multiple verticals as this market evolves. In addition, WaRP has been architected and designed from the ground up to address the key challenges faced in the wearables market, like battery life, connectivity, usability (user experience) and miniaturization (small form factors). In addition, WaRP is an open source platform, helping spur innovation within the development community.

The Platform

WaRP speeds and eases development for creating wearable devices by addressing technology challenges and freeing developers to focus on creating differentiated features. The platform consists of a main board and an example daughtercard with the ability to add additional daughtercards for different usage models. In addition to this modular approach, the platform also employs a unique hybrid architecture where there is an applications processor, i.MX 6SoloLite processor, as the core of the platform on the main board, and a secondary microcontroller, Kinetis KL16 MCU, on the daughtercard that is used as a sensor hub, in addition to a wireless charging MCU. All components included in this system were selected based on low power, small form factor and cost.

WaRP Block Diagram

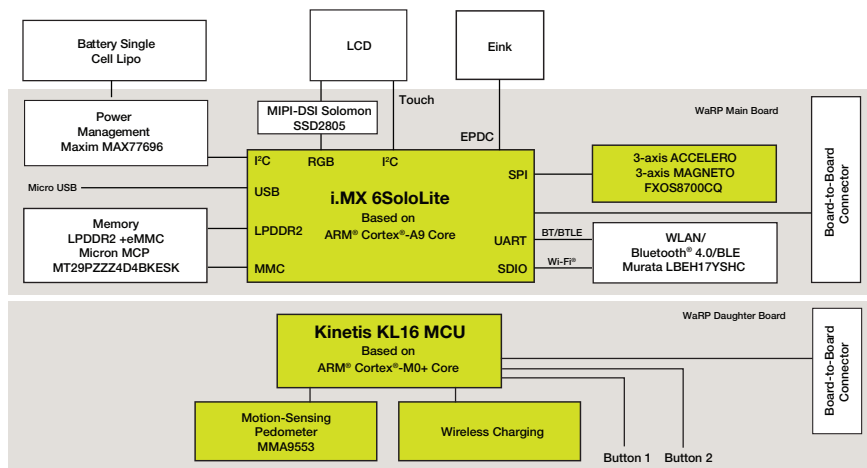

Freescle Technology

Target Applications

- Activity trackers
- Sports/heart rate monitors
- Smart watches
- ECG monitoring
- Smart glasses
- Smart clothing
- Wearable imaging devices
- Augmented reality headsets
- Wearable computing
- Wearable healthcare devices



The i.MX 6SoloLite processor is an efficient and powerful applications processor with low power and small form factor. This processor is based on a single-core ARM® Cortex®-A9 running up to 1 GHz with 256 KB of L2 cache and 32-bit DDR3/LPDDR2 support.

Targeted integration of multiple serial interfaces, EPD (E Ink® display) controller and an LCD controller makes the i.MX 6SoloLite processor ideal for next-generation wearable devices.

The Kinetis KL16 MCU is based on a 32-bit Cortex-M0+ which provides two times more CoreMark®/mA than the closest 8/16-bit architecture, implements multiple flexible low-power modes that reduces overall power and includes a rich suite of analog, communication, timing and control peripherals. Devices start from 32 KB of flash in a small footprint 5 x 5 mm² 32 QFN package, extending up to 256 KB in an 80 LQFP package. Software is provided to support wireless charging as an embedded solution with the Kinetis KL16 MCU.

With the hybrid architecture, the i.MX 6SoloLite processor is turned on to conduct the communications and support graphics/display; however, when in deep sleep mode, the MCU is triggered to monitor the sensor data. This method reduces overall power consumption, extending battery life.

Sensor technology is a critical component of wearable devices. WaRP incorporates Freescale sensors—the FXOS8700CQ accelerometer and magnetometer as well as the MMA9553 pedometer.

Other components in the system include a multi-chip memory module with 4 GB of managed NAND for storage and LP-DDR2 for application code, a Maxim power management IC, a Murata multi-radio connectivity module so data can be transmitted to a smartphone via Bluetooth® or Bluetooth Smart phone or directly to the cloud via Wi-Fi® and an LCD display (option for E Ink® display) for the user interface.

WaRP Features and Benefits

Feature	Benefit
WaRP includes a main application processor board and an add-on daughtercard for sensor aggregation and wireless charging	Provides a rapid prototyping vehicle, reducing time to market and freeing resources to focus on differentiation
Prevalidated connectivity with USB, Bluetooth, Bluetooth Smart and Wi-Fi	Allows for the wearable device to connect to a gateway such as a smartphone or directly to the cloud so that the data collected can provide value to the user
Component selection and board design optimized for low power and reduced form factor	Hardware schematics provided at no additional cost
LCD and low-power EPD (E Ink) display options with touchscreen	Flexible options to provide a rich user interface
Full-featured Android™ 4.3 operating system on the main application board along with a Standard Android SDK for developers	Supports extensive UI capabilities, connectivity stacks and eases development effort for software developers

WaRP: Enablement

On top of the hardware, the i.MX 6SoloLite processor runs Android™ 4.3. The implementation on WaRP is a standard Android SDK approach to allow software developers to run their applications simply and quickly. A not for profit, community-based organization provides service and support for WaRP. The solution's hardware and software are open sourced and community driven. A WaRP kit includes the main board, a sensor hub and wireless charging daughtercard, a battery and a touchscreen display module.

WaRP: Ecosystem

Freescale has collaborated with over 20 different companies to bring this platform to market. These companies include engineering designers, component suppliers and manufacturing partners.

WaRP: Capabilities

- Time, chrono, lap time, alarms
- Smart music player with audio streaming via Bluetooth
- Photo and video player
- Wi-Fi connectivity
- Compass
- Free fall detection

- Pedometer/activity monitor
- Wake-up on motion
- Charging over USB
- Wireless charging

WaRP: Technology Inside

- **Freescale i.MX 6SoloLite processor** based on Cortex-A9 architecture, operating up to 1 GHz and running Android 4.3
- **Freescale Kinetis MCU KL16** for sensor aggregation and wireless charging
- Freescale sensors (**FXOS8700CQ** and **MMA9553**) for orientation and pedometer functions
- Maxim MAX77696 power management IC
- Murata LBEH17YSHC Wi-Fi (802.11 b/g/n) and Bluetooth (4.0 Bluetooth Smart + EDR) wireless module
- Multi-chip package with LP-DDR2 and eMMC memories

For more information, please visit www.WaRPboard.org

Freescale, the Freescale logo and Kinetis are trademarks of Freescale Semiconductor, Inc., Reg. U.S. Pat. & Tm. Off. All other product or service names are the property of their respective owners. ARM and Cortex are registered trademarks of ARM Limited (or its subsidiaries) in the EU and/or elsewhere. All rights reserved. © 2014 Freescale Semiconductor, Inc.

Document Number: WARPFS REV 4

